

DRAWING NUMBER:
ART252JCAERO1929

7				8		
F	E	D	C	B	A	DRW REVISION
						INITIAL REVISION
						REVISION DSC
						SEE ECN
						REVISION DATE
						CHANGES

NOTES:

1. INSTALL/REMOVE PASSENGER SEATS IN ACCORDANCE WITH AMM SUPPLEMENT NO. JCAERO/AMM/0873-1.
2. THIS DRAWING TO BE READ IN CONJUNCTION WITH CHANGE ENGINEERING ORDER NO. JCAERO/EO/0873-1.
3. OUTBOARD ARMREST NOT TO PROTRUDE ACROSS EXIT APERTURE (THEREFORE IS TO BE A SHORT ARM OR NOT PRESENT) AND IS NOT TO IMPEDE OPENNING OF EXIT HATCH. HATCH MOUNTED ARMRESTS (HMAR) ARE NOT ACCEPTABLE.
4. PASSENGER SEAT LOCATIONS REFER TO CENTERLINE OF THE SEAT FRONT STUD. THE CENTERLINE OF SEAT FRONT STUD TO BE DEFINED AS MEASUREMENT POINT.
5. ALL MEASUREMENTS SHALL BE MADE WITH SEATS IN UPRIGHT POSITION, ARMRESTS DOWN AND FOODTRAY TABLES STOWED.
6. THE PASSENGER SEATS AT ROW 12 AND 13 L/H AND R/H ARE MODIFIED IN ACCORDANCE WITH MINOR CHANGE NO. 320_423 (EASA.21J.409) TO SUIT THE TYPE III EMERGENCY EXIT SEAT CONFIGURATION.
7. ALL PASSENGER SEATS ARE WITHOUT RECLINE.

FUNCTIONALITY AND CONFORMITY CHECKS

8. CHECK THAT EXIT SIGNS/MARKERS ARE NOT OBSTRUCTED.
9. CHECK THAT EACH SEAT IS EQUIPPED WITH AN (E)TSO APPROVED LIFE VEST.
10. CHECK THAT ALL "NO SMOKING" AND "FASTEN SEAT BELTS" SIGNS/MARKINGS ARE CLEARLY VISIBLE.
11. CHECK THAT OXYGEN DROP DOWN MASKS DEPLOY CORRECTLY I.A.W. THE AMM.
12. CHECK THAT THE TOTAL NUMBER OF OXYGEN MASKS EXCEEDS THE NUMBER OF PASSENGER SEATS BY 10%. THE EXTRA UNITS MUST BE EVENLY DISTRIBUTED THROUGHOUT THE CABIN AS PRACTICAL.
13. CHECK MINIMUM AISLE WIDTHS THROUGHOUT THE AIRCRAFT FOR CONFORMITY I.A.W. VIEW "SECTION A-A".
14. CHECK THAT SEAT ROW NUMBERING IS INSTALLED IN THE CORRECT LOCATIONS I.A.W. AIPC AND MATCH THE NEW SEATING LAYOUT.
15. CHECK THAT EACH PASSENGER SEAT AND CREW SEAT IS EQUIPPED WITH (E)TSO APPROVED SEAT BELT I.A.W. APPLICABLE SEAT CMM.
16. CHECK THAT MINIMUM DISTANCE FROM CUSHION REFERENCE POINT TO BULKHEAD IS GREATER THAN 35.00 INCHES. THE CRP IS DEFINED AS THE INTERSECTION OF THE TOP SURFACE OF BOTTOM CUSHION AND A CONSIDERATIONS VERTICAL LINE TANGENTIAL TO THE FORWARD MOST POINT OF THE SEAT BACK, MEASURED AT THE CENTER OF THE SEAT BACK WITH THE SEAT BACK IN THE FULL UPRIGHT POSITION. LITERATURE POCKETS OR OTHER EQUIPMENT INSTALLED ON BULKHEADS AT 18 INCHES OR HIGHER ABOVE THE FLOOR LEVEL SHALL BE CONSIDERED WITHIN THE HEAD STRIKE AREA.
17. CHECK THAT MINIMUM TYPE III EMERGENCY EXIT PASSAGEWAY REQUIREMENTS CONFORM WITH VIEW "DETAIL C".
18. CHECK THAT TYPE III EXIT HATCHES OPERATE WITHOUT INTERFERENCE IAW THE AMM.
19. CHECK THAT ALL NEW SEATS ARE SUPPLIED WITH AN EASA FORM 1.
20. CHECK THAT ALL FLOOR PATH LIGHTING IS VISIBLE WHEN ALL CABIN LIGHTING ABOVE 4 FEET IS EXTINGUISHED INCLUDING EXIT SPURS.
21. CHECK THAT THERE IS A MINIMUM OF 0.79 INCH CLEARANCE BETWEEN THE SEAT BACKREST AND FIXED MONUMENT, AND BETWEEN THE SEAT AND SIDEWALL.
22. CHECK THAT FOODTRAY TABLES ON TYPE III OVERWING EXIT SEATS CANNOT BE INADVERTENTLY DEPLOYED INTO THE EMERGENCY EXIT AISLE. ONE OF THE FOLLOWING CRITERIA MUST BE MET:
 - 22.1. FOODTRAY TABLE LATCHES OPERATE IN AN INBOARD DIRECTION ONLY, OR;
 - 22.2. FOODTRAY TABLE LATCHES ARE FULLY RECESSED BELOW THE SURROUNDING SEAT STRUCTURE.
23. CHECK THAT SEATS AT TYPE III OVER WING EMERGENCY EXITS DO NOT HAVE RECLINE OR BREAK OVER WHICH CAN INTERFERE WITH MINIMUM EMERGENCY EXIT AISLE WIDTHS AND DO NOT HAVE OUTBOARD ARMREST.
24. CHECK THAT EACH TYPE C EXIT HAVE ASSIST SPACE OF 12.00 x 20.00 INCHES AT ONE SIDE OF EXIT PASSAGEWAY ONLY. ASSIST SPACE MUST NOT INTERFERE WITH EXIT PASSAGEWAY.
25. CHECK THAT ALL SEATS PLACARDED WITH INSTRUCTIONS TO FASTEN SEAT BELTS AND WITH INFORMATION OF LIFE VEST LOCATION.
26. CHECK THAT PLACARDS CLEARLY INDICATE THE METHOD OF OPENING OF EACH TYPE III EXIT HATCH ARE LOCATED IN A PROMINENT POSITION & CLEARLY VISIBLE TO THE OCCUPANT OF EACH SEAT WHICH FORMS THE ACCESS ROUTE FROM THE CABIN AISLE TO THE TYPE III EXIT. ENSURE PRESENCE OF TYPE III HATCH OPENING INSTRUCTIONS PLACARD ON THE AFT FACE OF EACH FOODTRAY TABLE OR BACKREST OF THE SEAT IN ROW 11 & 12 (PLACARDS ARE VISIBLE TO THE PASSENGERS IN ROW 12 & 13).

TABLE 2

DESCRIPTION	ABBREVIATION
LEFT HAND	L/H
RIGHT HAND	R/H
CENTER	CTR
TRIPLE	TPL
DOUBLE	DBL
OUTBOARD	OUTBD
IN-ARM TABLE	IAT
RECLINE	REC
BREAKOVER	B/O
FOODTRAY	FDTR
LITERATURE POCKET	LP
NARROW	NRW
FORWARD	FWD
STANDARD	STD
TYPICAL	TYP
ASSEMBLY	ASSY
SEAT REFERENCE POINT	SRP
CUSHION REFERENCE POINT	CRP
EMERGENCY EXIT	EE

TABLE 1

SYMBOL	DESCRIPTION	ABBREVIATION
	SEAT WITH IN-ARM TABLE	IAT
	LITERATURE POCKET	LP
	SEAT WITH NO ARMREST	NO ARM
	SEAT WITH NO BREAK OVER	NO B/O
	SEAT WITH NO RECLINE	NO REC
	SEAT WITH NO FOODTRAY	NO FDTR
H	SEAT WITH HANDICAPPED FACILITIES	HDCP
A	CABIN ATTENDANT SEAT	CAS
L()	LAVATORY '()' - DESIGNATION LETTER	LAV
G()	GALLEY '()' - DESIGNATION DIGIT	GL

 J&C AERO EEU EASA APPROVAL NO: EASA.21J.580	WWW.THISISDOA.EU INFO@THISISDOA.EU PHONE: +353 1 5269768	AIRCRAFT: AIRBUS A320-214	TOLERANCES(UNLESS OTHERWISE SPECIFIED): ANGULAR =±5° DECIMALS X =±4 X.X =±0.4 X.XX =±0.04	DRAWN BY: SEE JCAERO/ECN/1929	
	MSN: 03631, 03644	REGISTRATION: -	SCALE: SIZE: NTS A2	ALL DIMENSIONS ARE IN INCHES THIRD ANGLE PROJECTION	CHECKED BY: SEE JCAERO/ECN/1929
	TITLE: 180 PAX [180Y] LAYOUT OF PASSENGER ACCOMMODATION				
	DRAWING NUMBER: ART252JCAERO1929		SHEET 1 OF 4		REV. A

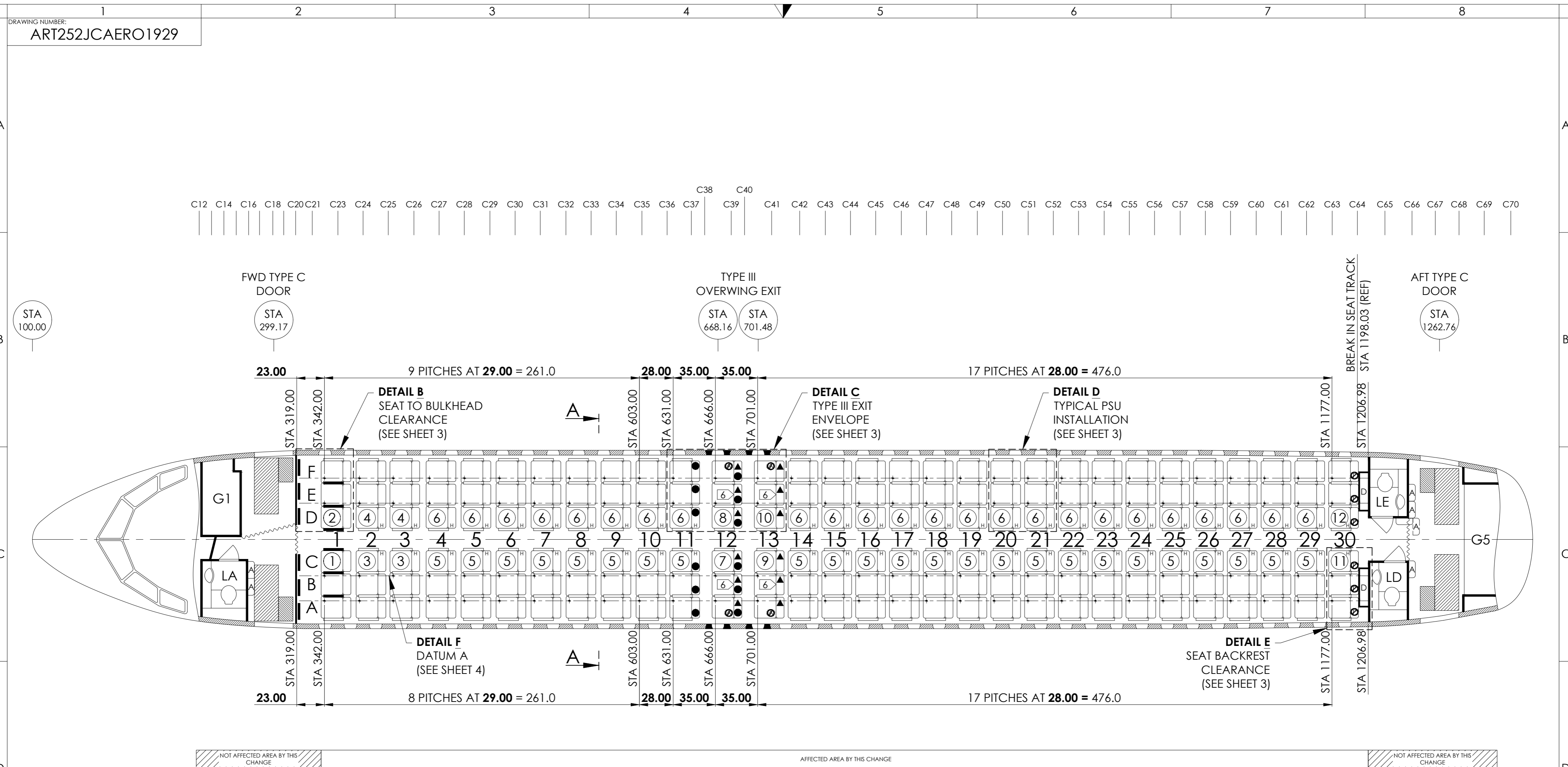

1 -101 INSTALLATION

1	12	3510H989-32-051	TRIPLE R/H SEAT - NO FDTR	RECARO	25-26-73	NEW	
1	11	3510H989-31-051	TRIPLE L/H SEAT - NO FDTR	RECARO	25-26-73	NEW	
1	10	3510H989-32-011	TRIPLE R/H SEAT - STD MODIFIED	RECARO	25-26-73	NEW	6
1	9	3510H989-31-011	TRIPLE L/H SEAT - STD MODIFIED	RECARO	25-26-73	NEW	6
1	8	3510H989-32-011	TRIPLE R/H SEAT - STD MODIFIED	RECARO	25-26-73	NEW	6
1	7	3510H989-31-011	TRIPLE L/H SEAT - STD MODIFIED	RECARO	25-26-73	NEW	6
24	6	3510H989-32-011	TRIPLE R/H SEAT - STD	RECARO	25-26-73	NEW	
24	5	3510H989-31-011	TRIPLE L/H SEAT - STD	RECARO	25-26-73	NEW	
2	4	3510H989-32-082	TRIPLE R/H SEAT - STD	RECARO	25-26-73	NEW	
2	3	3510H989-31-082	TRIPLE L/H SEAT - STD	RECARO	25-26-73	NEW	
1	2	3510H989-32-212	TRIPLE R/H SEAT - IAT	RECARO	25-26-73	NEW	
1	1	3510H989-31-212	TRIPLE L/H SEAT - IAT	RECARO	25-26-73	NEW	

- AIRBUS APPLICABLE DELIVERY DRAWING NO. D25286941 ISSUE D / DUAL CLASS 140 PAX [20J/120Y].
- PRE-MOD CAE PARC AVIATION DRAWING NO. 320-25266-DWG-01 / SINGLE CLASS 189 PAX [189Y].

QTY.	MAP REF.	ITEM No.	PART NUMBER	DESCRIPTION	MANU.	CMM	STATUS	NOTE
1								

<p>J&C AERO EEU</p> <p>EASA APPROVAL NO: EASA.21J.580</p>	<p>WWW.THISISDOA.EU INFO@THISISDOA.EU PHONE: +353 1 269768</p>	<p>AIRCRAFT: AIRBUS A320-214</p>	<p>TOLERANCES (UNLESS OTHERWISE SPECIFIED): ANGULAR ±25° DECIMALS X = ±4 X.X = ±0.4 X.XX = ±0.04</p>	<p>DRAWN BY: SEE JCAERO/ECN/1929</p>	
	<p>MSN: 03631, 03644</p>	<p>REGISTRATION: -</p>	<p>SCALE: SIZE: NTS A2</p>	<p>ALL DIMENSIONS ARE IN INCHES THIRD ANGLE PROJECTION</p>	<p>CHECKED BY: SEE JCAERO/ECN/1929</p>
	<p>TITLE: 180 PAX [180Y] LAYOUT OF PASSENGER ACCOMMODATION</p>				
	<p>DRAWING NUMBER: ART252JCAERO1929</p>			<p>SHEET 2 OF 4</p>	<p>REV. A</p>

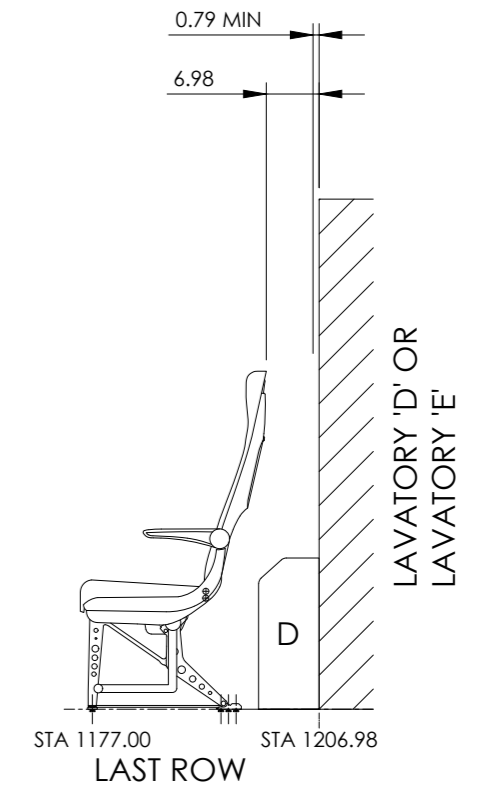
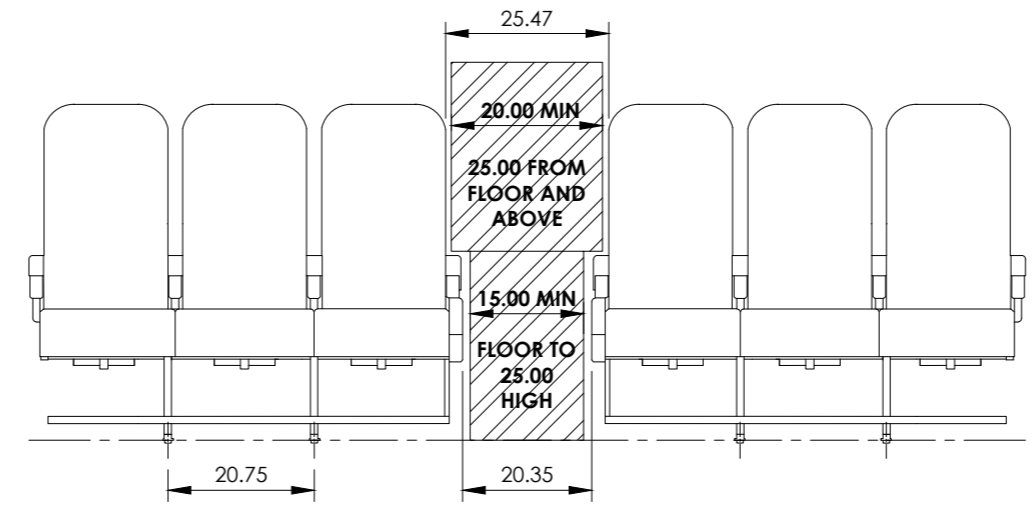
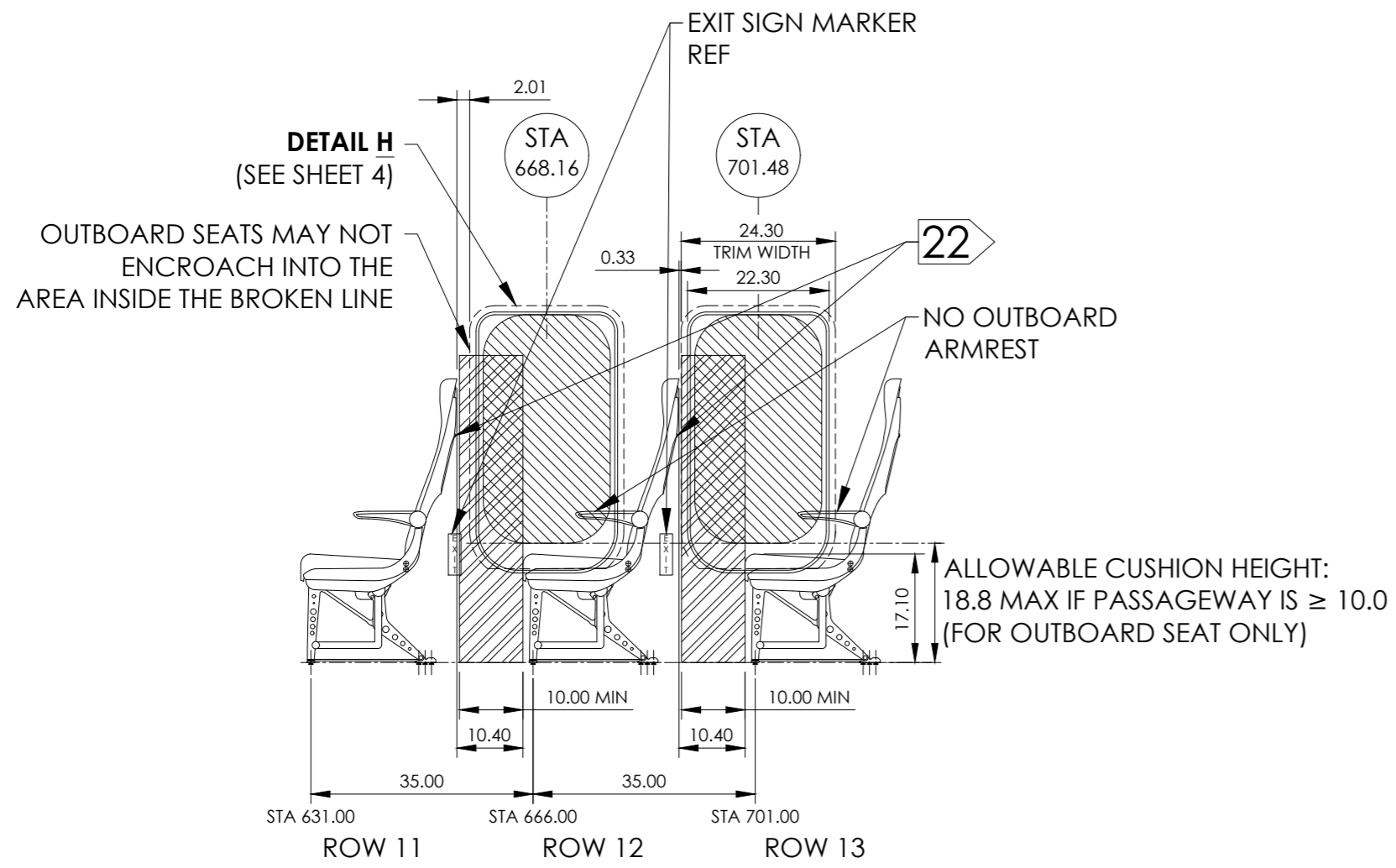

SECTION A-A - WIDTH OF AISLE
IAW JAR 25.815 - EXAMPLE SHOWN AT CONSTANT SECTION
(RECARO 3510H TYPE 989 SERIES SEATS)

DETAIL E
SEAT BACKREST CLEARANCE
R/H SHOWN (L/H SYMMETRICAL)
IAW AIRBUS FRAME SPECIFICATION NO. 2521 M1F 1000 00

3 **DETAIL C**
TYPE III EXIT PASSAGEWAY ENVELOPE & MAXIMUM CUSHION HEIGHT
R/H SHOWN (L/H SYMMETRICAL)
IAW AIRBUS FRAME SPECIFICATION NO. 2521 M1F 1000 00

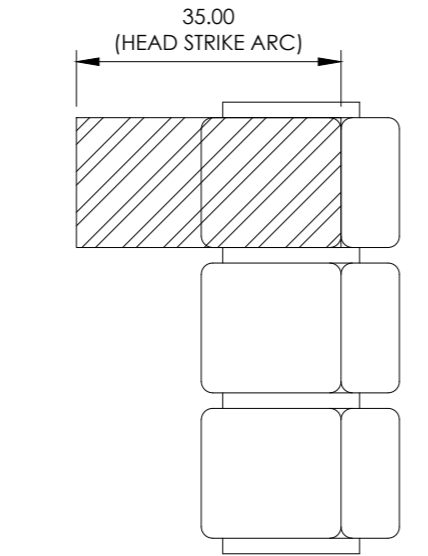
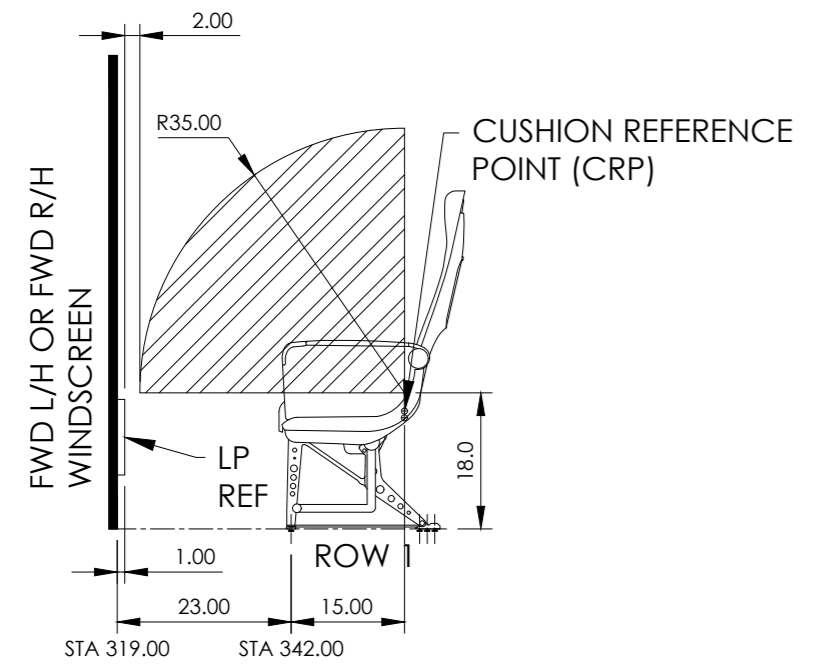

MINIMUM REQUIRED BULKHEAD CLEARANCE
35.00
(MEASURED FROM CUSHION REFERENCE POINT)

TYPICAL HEAD STRIKE ZONE
(AT EACH PAX PLACE - AFT OF BULKHEADS OR FIXED STRUCTURE)

DETAIL B
SEAT TO BULKHEAD CLEARANCE

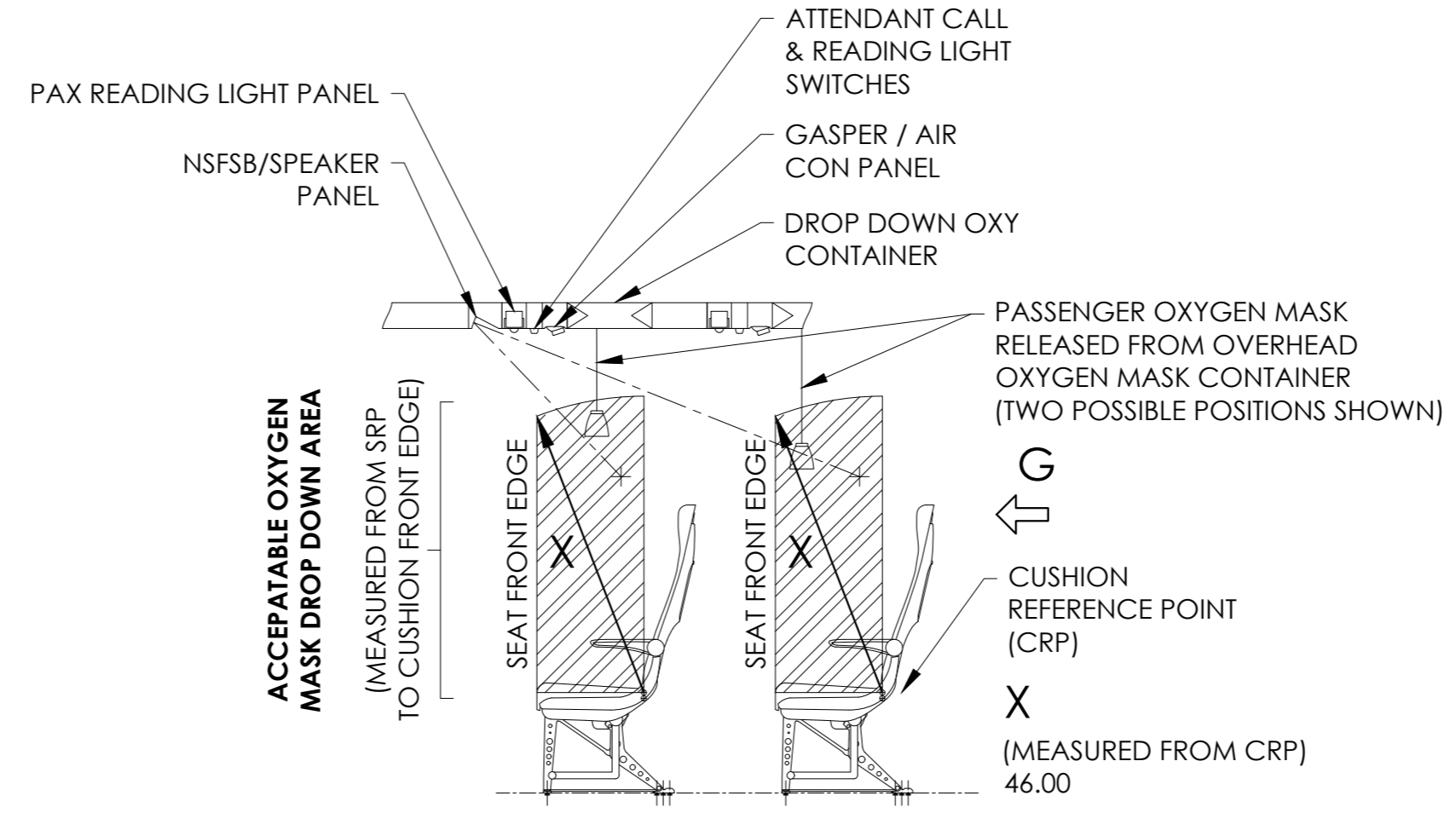

DETAIL D
TYPICAL PSU/PSIU ARRANGEMENT

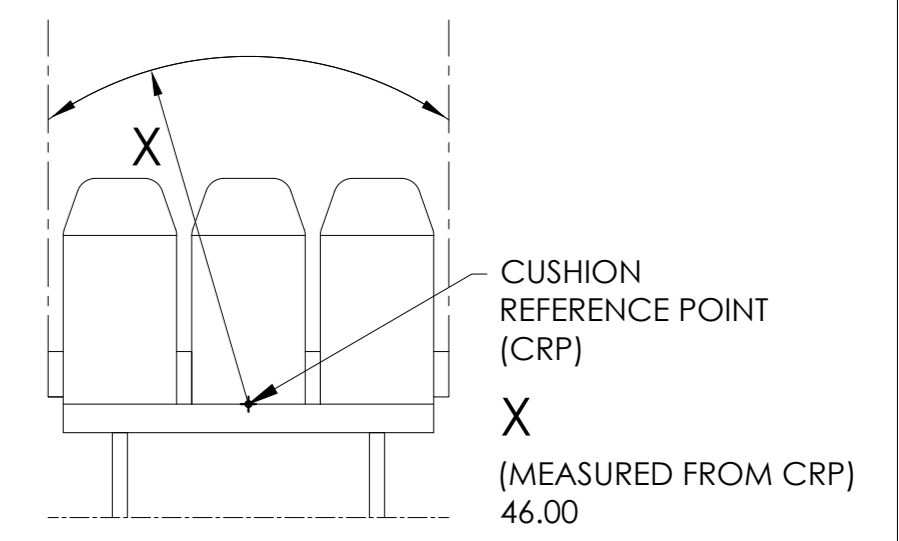

VIEW ON ARROW G
TYPICAL OXYGEN MASK DROP DOWN RADIUS

 J&C AERO EEU EASA APPROVAL NO: EASA.21J.580	WWW.THISISDOA.EU INFO@THISISDOA.EU PHONE: +353 1 5269768	AIRCRAFT: AIRBUS A320-214	TOLERANCES (UNLESS OTHERWISE SPECIFIED): ANGULAR = ±5° DECIMALS X = ±0.4 X.X = ±0.4 X.XX = ±0.04	DRAWN BY: SEE JCAERO/ECN/1929
	MSN: 03631, 03644	REGISTRATION: -	SCALE: SIZE: NTS A2	ALL DIMENSIONS ARE IN INCHES THIRD ANGLE PROJECTION
TITLE: 180 PAX [180Y] LAYOUT OF PASSENGER ACCOMMODATION				
DRAWING NUMBER: ART252JCAERO1929			SHEET 3 OF 4	REV. A

DRAWING NUMBER:
ART252JCAERO1929

DATUM A: X395.5
DATUM B: X701.5
DATUM C: X1156.5

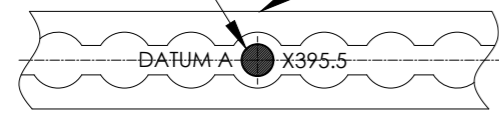

DETAIL F
DATUM A

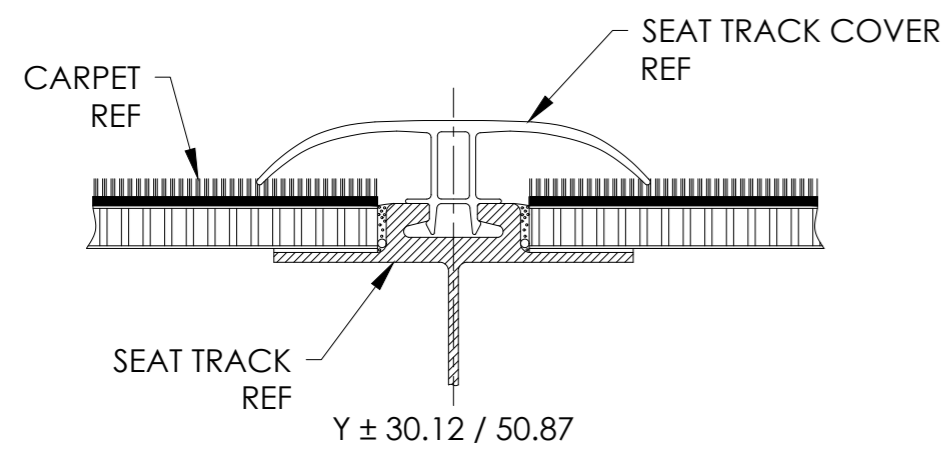

TYPICAL SEAT TRACK COVER INSTALLATION

Y ± 30.12 / 50.87

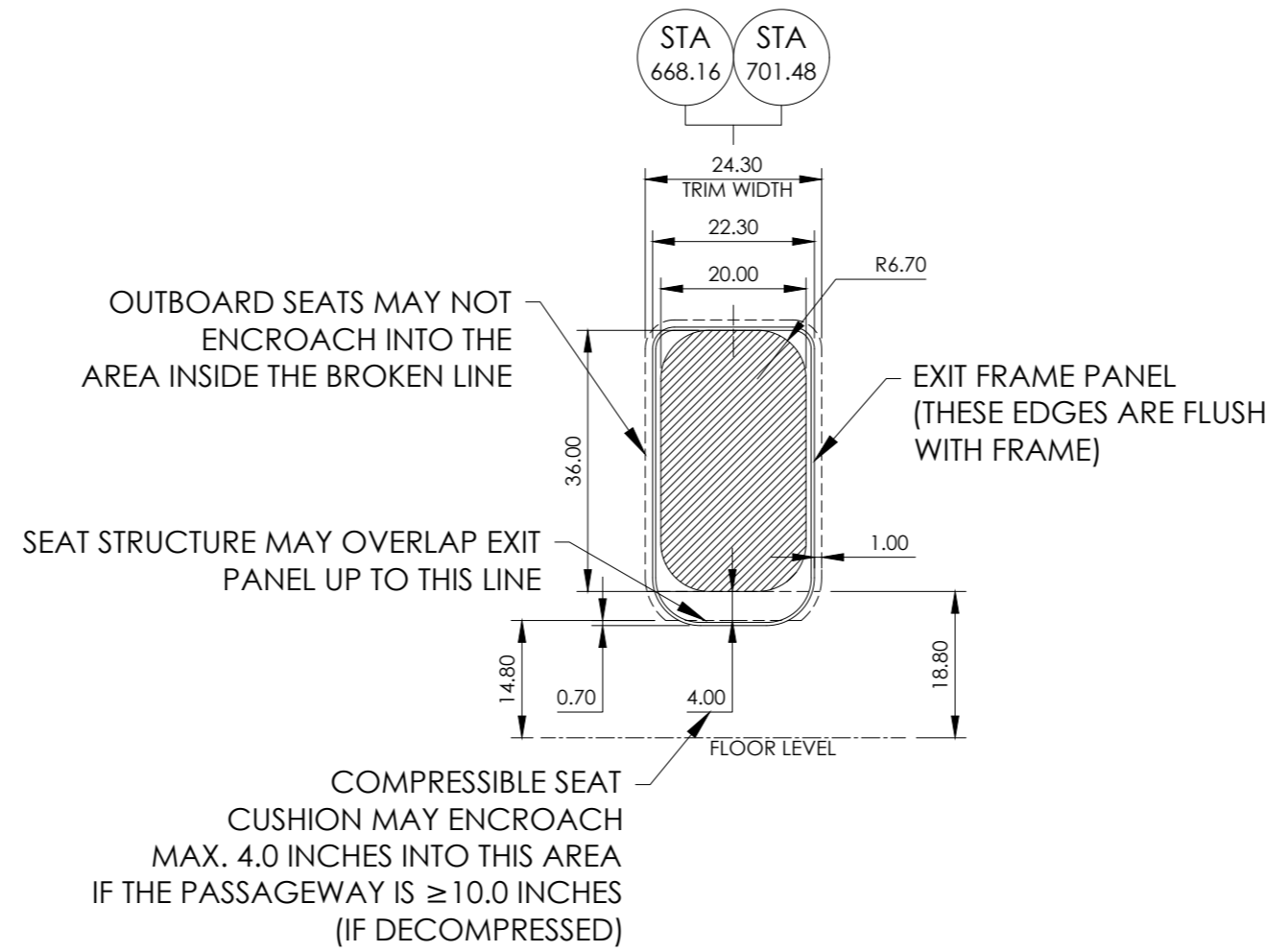

DETAIL H

TYPICAL TYPE III EMERGENCY EXIT HATCH ENVELOPE
IAW AIRBUS FRAME SPECIFICATION NO. 2521 M1F 1000 00

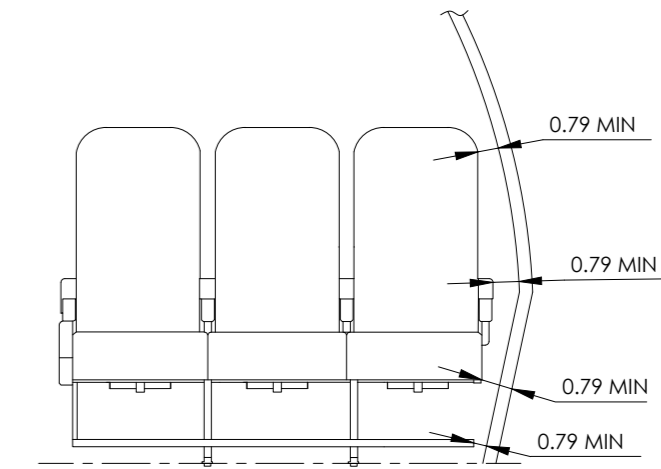

MINIMUM CLEARANCE FROM THE SIDEWALL
IAW AIRBUS FRAME SPECIFICATION NO. 2521 M1F 1000 00

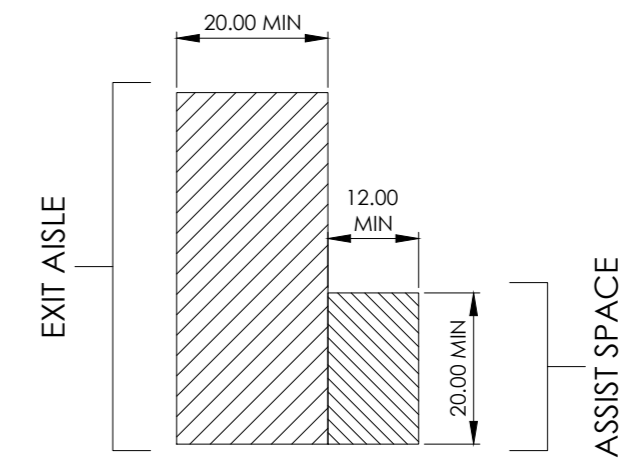

TYPICAL TYPE I, TYPE C DOOR EXIT AISLE & ASSIST SPACE
(REFER TO JAR 25.813 EMERGENCY EXIT ACCESS AND EASE OF OPERATION)

 WWW.THISISDOA.EU INFO@THISISDOA.EU PHONE: +353 1 5269768 EASA APPROVAL NO: EASA.21J.580	AIRCRAFT: AIRBUS A320-214	TOLERANCES (UNLESS OTHERWISE SPECIFIED): ANGULAR ±25° DECIMALS X = ±4 X.X = ±0.4 X.XX = ±0.04	DRAWN BY: SEE JCAERO/ECN/1929	
	MSN: 03631, 03644	REGISTRATION: -	CHECKED BY: SEE JCAERO/ECN/1929	
	TITLE: 180 PAX [180Y] LAYOUT OF PASSENGER ACCOMMODATION		SCALE: SIZE: NTS A2	ALL DIMENSIONS ARE INCHES THIRD ANGLE PROJECTION
	DRAWING NUMBER: ART252JCAERO1929		SHEET 4 OF 4	REV. A

© J&C AERO EEU LTD. OWN THE COPYRIGHT OF THIS DRAWING AND IT SHALL NOT BE REPRODUCED BY ANY OTHER WITHOUT THE PRIOR WRITTEN PERMISSION

DOC/002
ISSUE 1.0